

3000 PSI GENERAC

The Reliable Ones
High Pressure Washer
Owner's Manual

**Problems?
Questions?**
Before taking your unit
back to the store,
call the pressure washer
helpline at
1-800-270-1408
M-F 8-5 CST

This pressure
washer is
equipped with an
Automatic Cool
Down System.
See page 11 for
details.



Model No. 1124-0 (3000 PSI High Pressure Washer) Manual No. B2128 Revision 0 (2/27/98)



This symbol points out important safety instructions, which, if not followed, could endanger the personal safety and/or property of yourself and others. Read and follow all instructions in the manual before attempting to operate this unit.



⚠ CAUTION: Always disconnect spark plug wire and place wire where it cannot contact spark plug to prevent accidental starting when setting up, transporting, adjusting or making repairs to your high pressure washer.

- Engine exhaust gases contain DEADLY carbon monoxide gas. This dangerous gas, if breathed in sufficient concentrations, can cause unconsciousness or even death. Operate this equipment only in the open air where adequate ventilation is available.



WARNING:



The engine exhaust from this product contains chemicals known to the State of California to cause cancer, birth defects, or other reproductive harm.

- Gasoline is highly FLAMMABLE and its vapors are EXPLOSIVE. Do not permit smoking, open flames, sparks or heat in the vicinity while handling gasoline. Avoid spilling gasoline on a hot engine. Allow unit to cool for 2 minutes before refueling. Comply with all laws regulating storage and handling of gasoline.
- Locate this pressure washer in areas away from combustible materials, combustible fumes or dust.
- The high pressure equipment is designed to be used with Generac authorized parts only. If you use this equipment with parts that do not comply with minimum specifications, the user assumes all risks and liabilities.
- Some chemicals or detergents may be harmful if inhaled or ingested, causing severe nausea, fainting or poisoning. The harmful elements may cause property damage or severe injury.
- Do not allow CHILDREN to operate the Pressure Washer at any time.
- Operate engine only at governed speed. Running the engine at excessive speeds increases the hazard of personal injury. Do not tamper with parts which may increase or decrease the governed speed.
- Do not wear loose clothing, jewelry or anything that may be caught in the starter or other rotating parts.
- Before starting the Pressure Washer in cold weather, check all parts of the equipment and be sure ice has not formed there.
- Units with broken or missing parts, or without protective housing or covers should NEVER be operated.
- The muffler and air cleaner must be installed and in good condition before operating the Pressure Washer. These components act as spark arrestors if the engine backfires.
- Check the fuel system for leaks or signs of deterioration such as chafed or spongy hose, loose or missing clamps or damaged tank or cap. Correct all defects before operating the Pressure Washer.
- Do not spray flammable liquids.
- Never aim the gun at people, animals or plants.
- High pressure spray can cause paint chips or other particles to become airborne and fly at high speeds.
- The high pressure stream of water that this equipment produces can pierce skin and its underlying tissues, leading to serious injury and possible amputation.
- Always wear eye protection when you use this equipment or when you are in the vicinity where the equipment is in use.
- Never move the machine by pulling on the high pressure hose. Use the handle provided on the top of the unit.
- Always be certain the spray gun, nozzles and accessories are correctly attached.
- Never use a spray gun which does not have a trigger lock or trigger guard in place and in working order.
- Use a respirator or mask whenever there is a chance that vapors may be inhaled. Read all instructions with mask so you are certain the mask will provide the necessary protection against inhaling harmful vapors.
- High pressure spray may damage fragile items including glass. Do not point spray gun at glass when in the high pressure spray mode.
- Keep the hose connected to machine and the spray gun while the system is pressurized. Disconnecting the hose while the unit is pressurized is dangerous.
- Hold the spray gun firmly in your hand before you start the unit. Failure to do so could result in an injury from a whipping spray gun. Do not leave the spray gun unattended while the machine is running.
- The cleaning area should have adequate slopes and drainage to reduce the possibility of a fall due to slippery surfaces.
- Keep water spray away from electric wiring or fatal electric shock may result.
- Do not secure trigger gun in the pull-back (open) position.
- Do not by-pass any safety device on this machine.
- The muffler and engine heat up during operation and remain hot immediately after shutting it down. Avoid contact with a hot muffler or engine or you could be severely burned.
- Operate and store this unit on a stable surface.
- Never allow any part of the body to come in contact with the fluid stream. DO NOT come in contact with a fluid stream created by a leak in the high pressure hose.
- High pressure hose can develop leaks from wear, kinking, abuse, etc. Water spraying from a leak is capable of injecting material into skin. Inspect hose each time before using it. Check all hoses for cuts, leaks, abrasions or bulging of cover, or damage or movement of couplings. If any of these conditions exist, replace hose immediately. Never repair high pressure hose. Replace it with another hose that meets minimum pressure rating of your pressure washer.



CONGRATULATIONS on your purchase of a GENERAC high pressure washer. It has been designed, engineered and manufactured to give you the best possible dependability and performance.

Should you experience any problem you cannot easily remedy, please contact your nearest GENERAC Authorized Service facility, or call the 1-800 number listed on the front of this manual. We have competent, well-trained technicians and the proper tools to service or repair this unit.

Please read and retain this manual. The instructions will enable you to assemble and maintain your high pressure washer properly.

Model Number	1124-0
Serial Number	_____
Date of Purchase	_____

The model and serial numbers will be found on a decal attached to the pressure washer. You should record both serial number and date of purchase and keep in a safe place for future reference.

CUSTOMER RESPONSIBILITIES

- Read and observe the safety rules.
- Follow regular schedule in maintaining, caring for and using your high pressure washer.
- Follow the instructions under CUSTOMER RESPONSIBILITIES and STORAGE sections of this Owner's Manual.

PRODUCT SPECIFICATIONS

■ Pressure Washer Specifications

- Outlet Pressure** 3000 psi
- Flow Rate** 3.0 gallons per minute (gpm)
- Detergent Mix** Use undiluted detergent approved for pressure washers
- Water Supply Temperature** Not to Exceed 140°F
- Automatic Cool Down System** Will cycle when water reaches 140°-145°F

■ Engine specifications

- Engine Model** Briggs Vanguard
- Rated Horsepower** 9.0
- Displacement** 296cc
- Spark Plug**
 - Type** Champion RC12YC
 - Set Gap To:** 0.030 inch (0.76mm)
- Gasoline Capacity** 6.4 quarts
- Oil** SAE 30

In the State of California a spark arrestor is required by law (Section 4442 of the California Public Resources Code). Other states may have similar laws. Federal laws apply on federal lands.

NOTE: The spark arrestor must be maintained in effective working order by the owner/operator.

You can order a replacement spark arrestor through your authorized Generac service facility. See Engine Owner's Manual for part number.

KNOW YOUR PRESSURE WASHER

Read this owner's manual and safety rules before operating your high pressure washer. Compare the illustrations with your high pressure washer to familiarize yourself with the locations of various controls and adjustments. Save this manual for future reference.

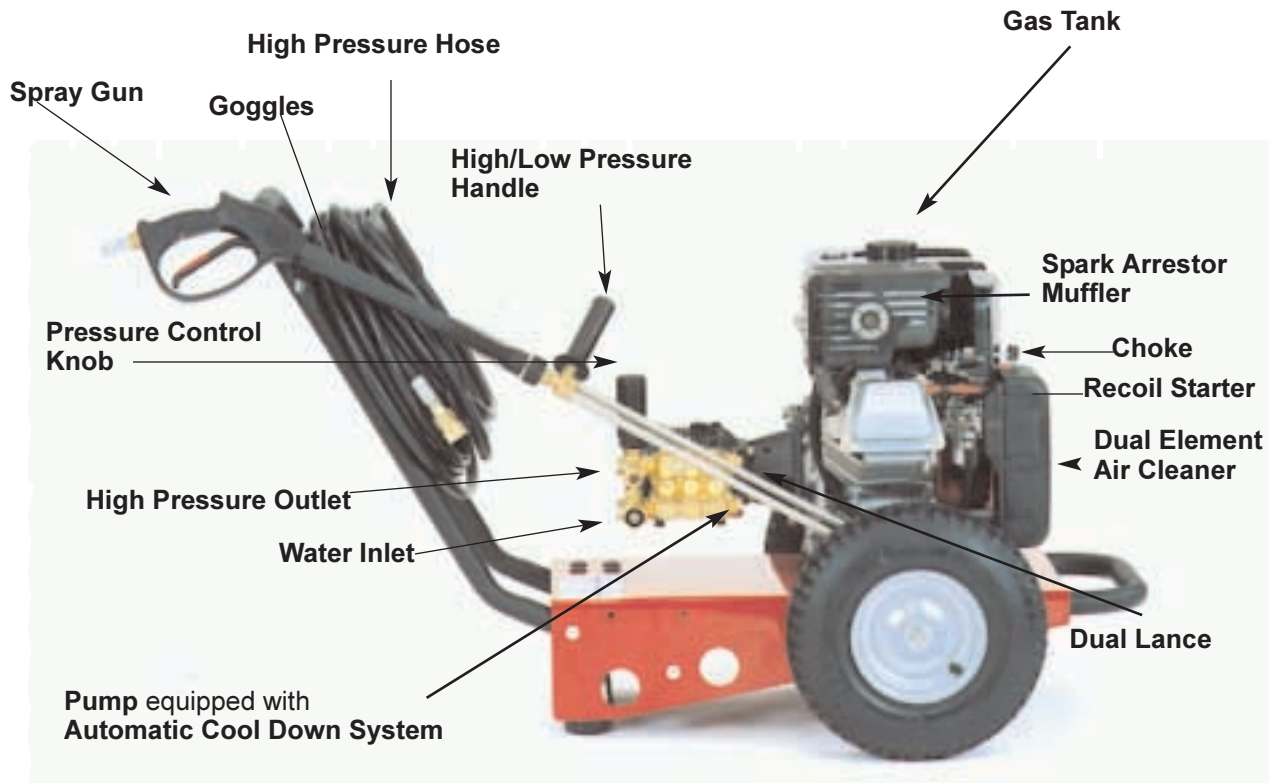

Pump — Develops high pressure.

Recoil Starter — Used for starting the engine manually.

Spray Gun — Controls the application of water and chemical onto cleaning surface with trigger device. Includes safety latch.

High/Low Pressure Handle — The handle allows you to select the high pressure spray or the chemical spray.

Dual Element Air Cleaner — Uses a dry type filter element and foam pre-cleaner to limit the amount of dirt and dust that gets in the engine.

Choke — Used when starting a cold engine.

Water Inlet — Connection for garden hose.

Dual Lance — Must be connected to the spray gun.

Spark Arrestor Muffler — Exhaust muffler lowers engine noise and is equipped with a spark arrestor screen, a USDA mandate for engine use in national forests and parks.

High Pressure Outlet — Connection for high pressure hose.

High Pressure Hose — Connect one end to water pump and the other end to spray gun.

Goggles — Always use the enclosed goggles or other eye protection when running your pressure washer.

Automatic Cool Down System — Cycles water through pump when water reaches 140°-145°F. **Warm water will discharge from pump onto base of unit. This system prevents internal pump damage.**

Pressure Control Knob — Rotated to switch between high and low pressure. Low pressure must be used when applying detergent.

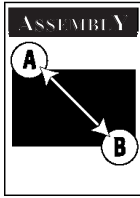

Read the entire owner's manual before you attempt to assemble or operate your new pressure washer. Your new pressure washer has been assembled at the factory with the exception of those parts left unassembled for shipping purposes.

REMOVE PRESSURE WASHER FROM CARTON

- Remove the parts box, packing material, and handle included with the pressure washer.
- Slice two corners at the engine starter recoil end of the carton from top to bottom so the panel can be folded down flat, then remove all packing material.
- Roll the pressure washer out of the carton

CARTON CONTENTS

Items in the carton include:

- Main Unit
- Manual Bag
 - Owner's Manual
 - Pump Manual
 - Engine Owner's Manual
 - Handle
- Parts Box (which includes the following):
 - Goggles
 - Spray Gun
 - Dual Lance
 - High Pressure Hose
 - Nozzle Cleaning Kit
 - Handle Parts Bag (which includes the following):
 - 4 carriage bolts
 - 2 carriage (J) hooks
 - 2 carriage hook caps
 - 6 hex nuts

If any of the above parts are missing or damaged, call the Pressure Washer Helpline at **1-800-270-1408**.

PREPARING THE PRESSURE WASHER FOR USE

If you have any problems with the assembly of your pressure washer or if parts are missing or damaged, call the Pressure Washer Helpline at **1-800-270-1408**.

To prepare your pressure washer for operation you will need to perform these tasks:

- Attach the handle and attach the carriage hooks that holds the spray gun and chemical bottle.
- Connect the high pressure hose to the spray gun and the pump and connect water supply to the pump.
- Add oil to engine crankcase.
- Add fuel to fuel tank.

■ Attach the Handle

- Place the bottom of the handle into the openings in the base unit making sure the holes in the handle align with the holes in the base (Figure 1).

Figure 1 — Attach the handle to the base.

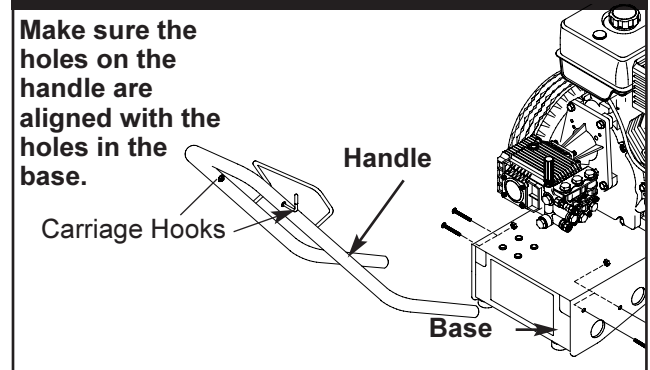

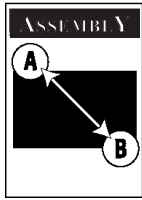

- Insert the carriage bolts from the outside through the holes in the baseplate and through the handle and attach the hex nuts on the inside. Tighten them with a 1/2" wrench.
- Insert the J hooks in the holes in the handle located on both sides of the unit and affix them with the remaining hex nuts. Tighten them with a 1/2" wrench.

■ Add Engine Oil

IMPORTANT: Any attempt to crank or start the engine before it has been properly serviced with the recommended oil may result in an engine failure.

Note: When adding oil to the engine crankcase, use only high quality detergent oil rated with API service classification SE, SF, or SG rated SAE 30 weight. Select the oil's viscosity grade according to your expected operating temperature. **DO NOT Use SAE 10W40 Oil.**

Although multi-viscosity oils (5W30, 10W30, etc.) improve starting in cold weather, these multi-viscosity oils will result in increased oil consumption when used above 32°F. Check your engine oil level more frequently to avoid possible damage from running low on oil.

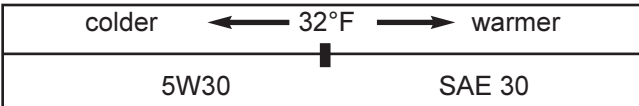

- Place pressure washer on a level surface.
- Clean area around oil fill and remove black oil fill cap (Figure 2).

Figure 2 – Add oil to engine crankcase. Do not attempt to start engine without adding oil.

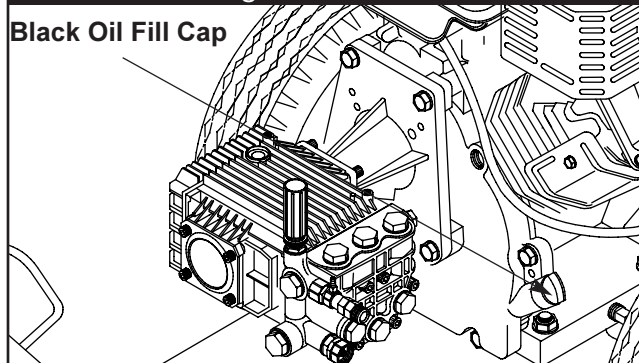

- Pour oil into the oil fill opening until it reaches the top. **DO NOT OVERFILL.** Check often when filling.
- Install black oil cap, hand tighten securely.

Note: Check Oil Often During Engine Break-in.

■ Add Gasoline

! DANGER! Never fill fuel tank indoors. Never fill fuel tank when engine is running or hot. Do not smoke when filling fuel tank.

! WARNING! Never fill fuel tank completely full. Fill tank to about 1/2" below the bottom of the filler neck to provide space for fuel expansion. Wipe away any fuel spillage from the engine and equipment before starting.

The manufacturer recommends fresh, clean unleaded automotive gasoline.

- Use clean fuel and store in approved, clean, covered containers. Use clean fill funnels. Never use "stale" gasoline left over from last season or gasoline stored for long periods.
- Clean area around fuel fill cap, remove cap (Figure 3).

Figure 3 – Add gasoline to fuel tank.

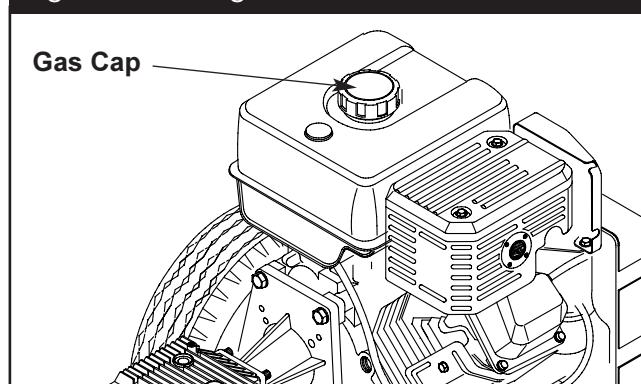

- Add "UNLEADED" gasoline, slowly, to fuel tank. Use a funnel to prevent spillage.
- Install fuel cap and wipe up any spilled gasoline.

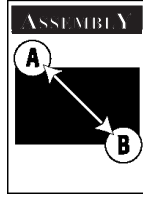

■ Connect Hose and Water Supply to Pump

IMPORTANT: You must connect the gun to the dual lance and attach all hoses before you start the engine. Starting the engine without all hoses connected and the water supplied will damage the pump.

- Uncoil the high pressure hose and attach the end of the hose with the quick connect to the base of the spray gun (Figure 4). Tighten by hand.

Figure 4 – Connect high pressure hose to spray gun.



- Attach the other end of the high pressure hose to the high pressure outlet on the pump (Figure 5). Tighten by hand.
- Before you connect your garden hose to the water inlet, inspect the water inlet screen (see Figure 6). Clean the screen if it contains debris or have it replaced if damaged. **Do not run the pressure washer if the water inlet screen is damaged.**
- Connect the garden hose to water inlet. Tighten firmly by hand (Figure 6).
- Turn on the water (open valve completely).
- Squeeze the trigger on the gun to purge the pump system of air and impurities. Squeeze until a steady stream appears.
- Attach the dual lance to spray gun. Tighten by hand (Figure 7).



Warning: Before starting the pressure washer, be sure you are wearing adequate eye protection.

Figure 5 – Connect high pressure hose to pump.

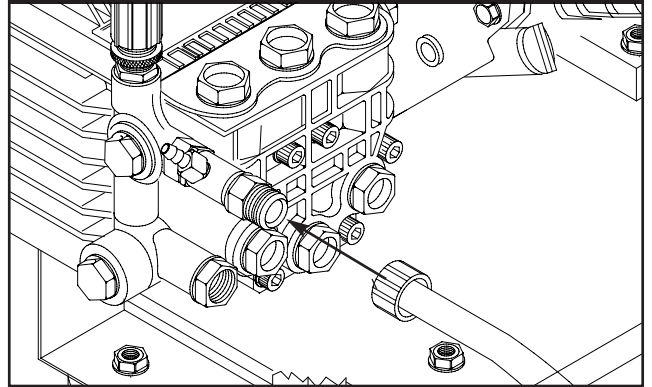

Figure 6 – Connect garden hose to water inlet and turn ON water.

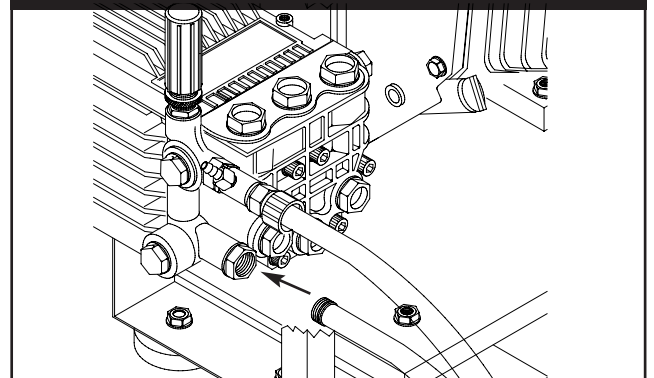
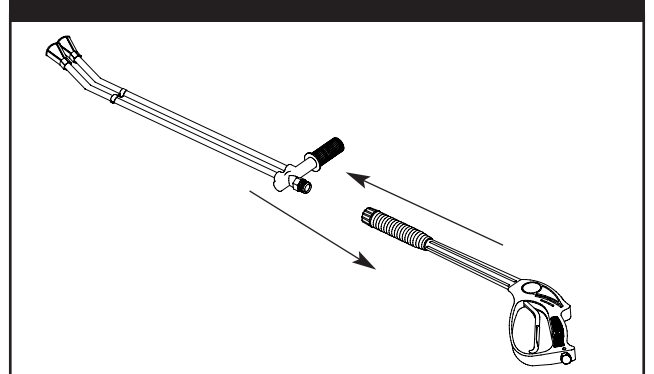
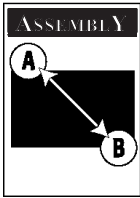

Figure 7 – Connect dual lance to spray gun.





USING THE NOZZLES

The chemical nozzle, which is permanently affixed to your dual lance and has a spray pattern of 25 degrees, must be used when applying chemical. The other nozzle attached to the lance has a 15 degree spray pattern and is used when rinsing. There are four accessory nozzles that may be purchased that are used when rinsing. Each has a different spray pattern, as indicated in the following illustration (Figure 8). Please note that if you choose to purchase these nozzles, you must also buy a quick connect adaptor.

In order to change the accessory nozzle being used, simply pull back the collar on the quick connect and pull the current nozzle off. To put one on, pull back the collar, insert the new nozzle and release the collar, making sure it becomes flush with the end of the quick connect. This procedure is only used when utilizing the accessory nozzles that may be purchased.

Figure 8 – Spray patterns of nozzles

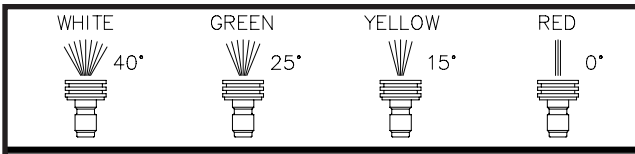

CHECKLIST BEFORE STARTING ENGINE

If you have reached this point, look back over the assembly to see if you have performed all of the following.

- Check for properly tightened hose connections (high pressure and water supply) and for tight connections and that there are no kinks, cuts, or damage to the high pressure hose, or garden hose.
- Check that oil has been added to proper level in engine crankcase before trying to start the pressure washer.
- Add proper gasoline to fuel tank.
- Provide proper water supply (not to exceed 140°F).
- Be sure to read “Safety Rules” and “Operation” sections before using the pressure washer.



HOW TO USE YOUR PRESSURE WASHER

If you have any problems operating your pressure washer, please call the pressure washer helpline at **1-800-270-1408**.

You have assembled your high pressure washer and have prepared the engine for starting. You are now ready to clean your car, boat, the outside of a building or whatever you plan to clean.

■ How to Start Your Engine

The best way to start your engine-powered pressure washer for the first time is to follow these instructions step-by-step. This starting information also applies whenever you start the engine after you have let the pressure washer sit idle for at least a day.

- This pressure washer requires a water source that flows at least 3.0 gallons per minute. **Do not attempt to siphon water from a non-pressurized container.** Place the pressure washer close enough to an outside water source so that no more than 50' of garden hose is needed.
- Check that the high pressure hose is tightly connected to the spray gun and to the pump. See ASSEMBLY section for illustrations.
- **Connect the garden hose to water inlet on the pressure washer pump and turn the water valve on all the way.**

IMPORTANT: Do not run the pump without the water supply connected and turned on. You must follow this caution or the pump will be damaged.

- Turn fuel shut-off valve 1/4 turn to OPEN position.
- Move choke control to CHOKE position.
- Move throttle control to FAST position.
- Push RUN/STOP switch to RUN position.

Note: For a warm engine, do not choke.

- Squeeze the trigger on the spray gun to relieve water pressure caused by turning on the water. Water will spew out of the gun in a thin stream. Continue to hold the trigger until you have a steady stream of water and no air remains. This will make it easier to pull start the engine. Release the trigger.

- Apply the safety latch to the spray gun trigger (Figure 9).

Figure 9— Safety Latch.

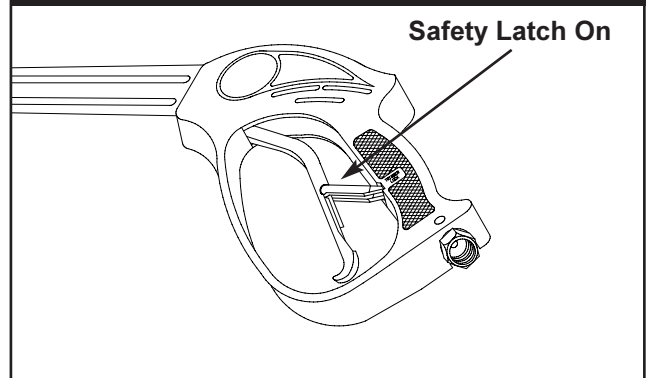

- Grasp rope handle and pull slowly until you feel some resistance. Then pull cord rapidly to overcome compression, prevent kickback and start the engine. Let rope return to starter slowly. Repeat if necessary with choke off and throttle control in FAST. Operate engine with choke in RUN and throttle in FAST position.

If after 3 pulls the engine fails to start, disengage the spray gun safety latch, squeeze the trigger to relieve water pressure, re-engage the spray gun safety latch and pull the recoil starter handle rapidly (Max. 3 pulls).

■ How to Stop Your Pressure Washer

- Move throttle control to SLOW position.
- Push RUN/STOP switch to STOP position.
- Turn fuel shut-off valve 1/4 turn to CLOSED position..
- Simply shutting off the engine will not release pressure in the system. **Squeeze trigger on the spray gun to relieve pressure in the hose.**

Note: A small amount of water will squirt out when you release the pressure.



■ How to Use the Dual Lance and Adjust Pressure

You now should know how to **START** your pressure washer and how to **STOP** it. The information in this section will tell you how to adjust the pressure and apply detergent or any other cleaning chemicals.

IMPORTANT: You must **attach all hoses** and **turn on the water** source fully before you start the engine. Starting the engine without all the hoses connected and without the water turned on will damage the pump.

⚠ DANGER! Never put hands in front of nozzle.

- Located on the side of the pump is a pressure control knob. You can increase and decrease the pressure of the spray by turning the knob clockwise or counterclockwise respectively (Figure 10). The unit has been set to maximum at the factory.

Figure 10 – Pressure control knob.

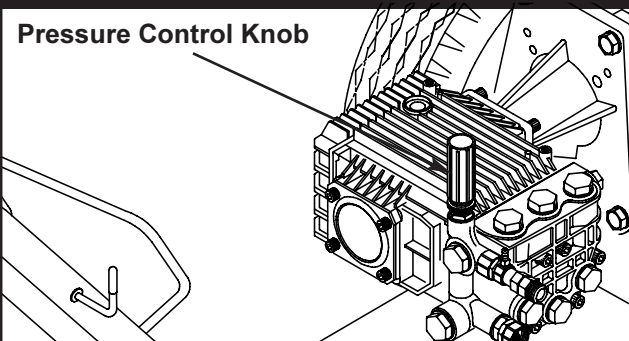

- Point the nozzle in a safe direction and squeeze the trigger to test the pressure. Be careful not to spray your feet.
- For most effective cleaning, keep the spray nozzle between 8 to 24 inches away from cleaning surface.
- If you get spray nozzle too close, especially using high pressure, you may damage the cleaning surface.
- Do not get closer than 8 inches when cleaning tires.

■ Applying Detergent

IMPORTANT: Use soaps designed specifically for pressure washers. Household detergents could damage the pump.

To apply detergent follow these steps:

- Turn the valve on the dual lance to low pressure.
- Prepare the detergent solution as required by the job.
- Hang the detergent solution on the J hook on the handle.
- Place the small filter end of the chemical injecting tube into the detergent container .

IMPORTANT: Detergent **cannot** be applied without the water source turned on.

- Make sure garden hose is connected to water inlet. Check that high pressure hose is connected to spray gun and pump (see the ASSEMBLY section), and start engine.
- Apply the detergent to a dry surface, starting from the bottom and working up to avoid streaking.
- Allow the detergent to soak in for 3-5 minutes before washing and rinsing. Reapply detergent to prevent surface from drying.
- For washing, start at lower portion of area to be washed and work upward, using long, even, overlapping strokes.

⚠ CAUTION: Keep the plastic chemical injecting tube from coming in contact with the hot muffler. This will damage the plastic tube. When inserting the filter into a cleaning agent bottle, route the tube so as to keep it from inadvertently contacting the hot muffler.



■ Pressure Washer Rinsing

⚠ WARNING: Be extremely careful if you must use the pressure washer from a ladder, scaffolding or any other relatively unstable location. Pressure in a running washer builds as you climb. When you press the trigger, the recoil from the initial spray could force you to fall. The high pressure spray could also force you to fall if you are too close to the cleaning surface.

For Rinsing:

- Remove the chemical injector hose from the chemical bottle to stop detergent from flowing. Spray until the detergent has cleared from the gun.
- Keep the spray gun a safe distance from the area you plan to spray.
- Apply a high pressure spray to a small area and then check the surface for damage. If no damage is found, you can assume it is okay to continue cleaning.
- Start at top of area to be rinsed, working down with same overlapping strokes as you used for cleaning.

■ Automatic Cool Down System (Thermal Relief)

If you run the engine on your pressure washer for 3-5 minutes without pressing the trigger on the spray gun, circulating water in the pump can reach a temperature between 140–145°F. When the water reaches this temperature, the automatic cool down system engages and cools the pump by **discharging the warm water onto the ground**. This system prevents internal damage to the pump.

GENERAL MAINTENANCE RECOMMENDATIONS

The warranty of the high pressure washer does not cover items that have been subjected to operator abuse or negligence. To receive full value from the warranty, operator must maintain high pressure washer as instructed in this manual.

- Some adjustments will need to be made periodically to properly maintain your high pressure washer.
- All adjustments in the Service and Adjustments section of the engine owner's manual should be made at least once each season.
- Once a year you should clean or replace the spark plug, clean or replace the air filter and check the gun and dual lance assembly for wear. A new spark plug and clean air filter assure proper fuel-air mixture and help your engine run better and last longer.

■ BEFORE EACH USE

- Check engine oil level.
- Check water inlet screen for damage.
- Check high pressure hose for leaks.
- Check detergent inlet hose and filter for damage.
- Check gun and dual lance assembly for leaks.

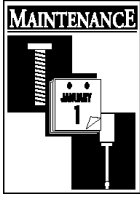

PRESSURE WASHER MAINTENANCE

■ Check and Clean Inlet Screen

Examine screen on the water inlet. Clean if the screen is clogged or replace if screen is damaged.

■ Check High Pressure Hose

High pressure hose can develop leaks from wear, kinking, or abuse. Inspect hose each time before using it. Check for cuts, leaks, abrasions or bulging of cover, damage or movement of couplings. If any of these conditions exist, replace hose immediately.



DANGER: Water spraying from a leak is capable of injecting material into skin. Inspect hose each time before using it. Never repair a high pressure hose. Replace it with another hose that meets the maximum pressure rating of your pressure washer.

■ Check Chemical Injecting Tube

Examine the filter on the chemical injecting tube and clean if clogged. The tube should fit tightly on barbed fitting. Examine the tube for leaks or tears. Replace the filter or tube if either is damaged.

■ Check Gun and Dual lance

Examine hose connection to gun and make sure it is secure. Test trigger by pressing it and making sure it springs back into place when you release it. Put safety latch in **on** position and test trigger. You should not be able to press trigger.

■ Purge Pump of Air and Contaminants

To remove the air from the pump, follow these steps:

- Set up the pressure washer as described in the ASSEMBLY section and connect the water supply.
- Remove the dual lance from the gun.
- Squeeze the trigger on the gun and hold.

To remove any contaminants from the pump, follow these steps:

- Set up the pressure washer as described in the ASSEMBLY section, and connect the water supply.

- Remove the dual lance from the spray gun.
- Start the engine according to instructions in OPERATION section.
- Squeeze the trigger on the spray gun and hold.
- When the water supply is steady and constant, engage the safety latch and refasten the dual lance.

■ Cleaning Chemical Injecting Tube

If you have used the chemical injecting tube you must flush it with clean water before stopping the engine.

To clean the chemical injector hose:

- Place the small filter end of the chemical injecting tube in a bucket of clean water.
- Open the chemical valve handle fully on the lance by turning it counterclockwise. This puts the gun in low pressure.
- Squeeze the spray gun trigger for 1-2 minutes to flush the chemical injector hose.
- Shut off the engine.

Important: Simply shutting OFF engine will not release pressure in the system. **When the engine has shut down, squeeze the trigger on the spray gun to relieve the pressure in the hose.**

■ Nozzle Maintenance

If the nozzle on the dual lance becomes restricted or clogged with foreign materials, such as dirt, excessive pump pressure may develop. If this nozzle becomes partially clogged, it can cause a pulsing sensation during use. This generally is not a pump related problem, but rather a clogged or partially restricted nozzle.

If the nozzle becomes clogged or partially restricted, immediately clean the nozzle with the kit included with your pressure washer by following these instructions:

- Shut off the engine and turn off the water supply.
- Press trigger to relieve pressure.
- Separate the dual lance from the spray gun.
- Use the wire included in the kit or a small paper clip to free the foreign materials clogging or restricting the nozzle (Figure 11).

Figure 11 — Removing and cleaning nozzle.

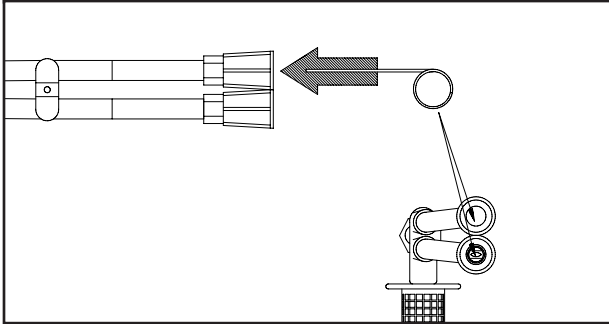

- Remove additional debris by back flushing the water supply through the dual lance (Figure 12). Back flush between 30 to 60 seconds. Back flush both lances by turning chemical valve handle.

Figure 12 — Backflushing the nozzle.

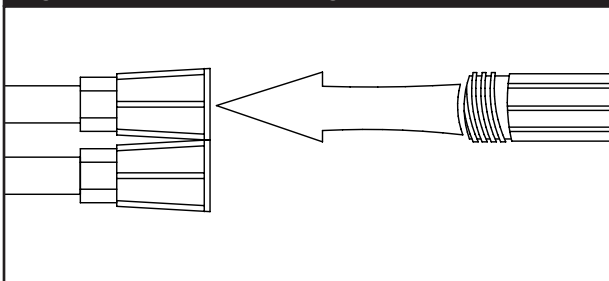

- Reconnect the dual lance to the spray gun.
- Reconnect the water supply, turn on the water, and start the engine.
- Test the pressure washer by operating with the nozzle in the high and low pressure positions.

ENGINE MAINTENANCE

See the engine Owner's Manual for instructions on how to properly maintain the engine.

SERVICE AND ADJUSTMENTS

See the Engine Owner's Manual for instructions on how to properly service and adjust the engine

PREPARING THE UNIT FOR STORAGE

Water should not remain in the unit for long periods of time. Sediments of minerals can deposit on pump parts and "freeze" pump action. If you do not plan to use the pressure washer for more than 30 days, follow this procedure:

1. Flush the chemical injecting tube by placing the injector filter into a pail of clean water while running pressure washer and squeezing the spray gun trigger with the dual lance in low pressure mode. Flush for 1-2 minutes.
2. Shut off the engine and let it cool, then remove all hoses.
3. Place Run/Stop Switch in STOP position.
4. Empty the pump of all liquids by pulling recoil handle about 6 times. This should remove most of the liquid in the pump.

- NOTE:** To protect the unit from freezing temperatures, draw antifreeze fluid into pump by pouring antifreeze fluid into a 3-foot section of garden hose connected to the inlet adapter and pulling the recoil handle twice. Use non-alcohol, RV antifreeze only.
5. Store in a clean, dry area.

STORING THE ENGINE

See the Engine Owner's manual for instructions on how to properly store the engine.



TROUBLESHOOTING POINTS

Problem

Pump has the following problems:
failure to produce pressure, erratic pressure, chattering, loss of pressure, low water volume.

Cause

1. Lance is in low pressure mode.
2. Water inlet is blocked.
3. Inadequate water supply.
4. Garden hose is kinked or leaking.
5. Inlet hose strainer is clogged.
6. Water supply is over 140°F.
7. Outlet hose is blocked or leaks.
8. Gun leaks.
9. Nozzle is obstructed.
10. Pump is faulty.

Correction

1. Adjust chemical valve handle to high pressure.
2. Clear inlet.
3. Provide adequate water flow.
4. Straighten garden hose, patch leak.
5. Check and clean water inlet screen.
6. Provide cooler water supply.
7. Clear blocks in outlet hose.
8. Replace gun.
9. Clear nozzle.
10. Contact Generac service facility.

Detergent fails to mix with spray.

1. Chemical injecting tube is not submerged.
2. Chemical injecting tube is clogged.
3. Chemical valve handle is in high pressure mode
4. Chemical concentration knob is closed.

1. Insert chemical injecting tube into detergent.
2. Clean or replace filter/chemical injecting tube.
3. Adjust chemical valve handle to low pressure mode.
4. Open chemical concentration knob.

Engine runs well when not spraying but "bogs down" when the trigger is squeezed.

Engine speed is too slow.

Contact Generac service facility.



TROUBLESHOOTING POINTS

PROBLEM	CAUSE	CORRECTION
<p>Engine will not start; or starts and runs rough.</p>	<ol style="list-style-type: none"> 1. Low oil level. 2. Dirty air cleaner. 3. Out of gasoline. 4. Stale gasoline. 5. Spark plug wire not connected to spark plug. 6. Bad spark plug. 7. Water in gasoline. 8. Excessively rich fuel mixture. 9. Intake valve stuck open or closed. 10. Engine has lost compression. 	<ol style="list-style-type: none"> 1. Fill crankcase to proper level. 2. Clean or replace air cleaner. 3. Fill fuel tank. 4. Drain gas tank; fill with fresh fuel. 5. Connect wire to spark plug. 6. Replace spark plug. 7. Drain gas tank; fill with fresh fuel. 8. Contact Generac service facility. 9. Contact Generac service facility. 10. Contact Generac service facility.
<p>Engine shuts down during operation.</p>	<ol style="list-style-type: none"> 1. Out of gasoline. 2. Low oil level. 	<ol style="list-style-type: none"> 1. Fill fuel tank. 2. Fill crankcase to proper level.
<p>Engine lacks power.</p>	<p>Dirty air filter.</p>	<p>Replace air filter.</p>
<p>Engine "hunts" or falters.</p>	<p>Engine not operating properly.</p>	<p>Contact Generac service facility.</p>

EXPLODED VIEW — PRESSURE WASHER

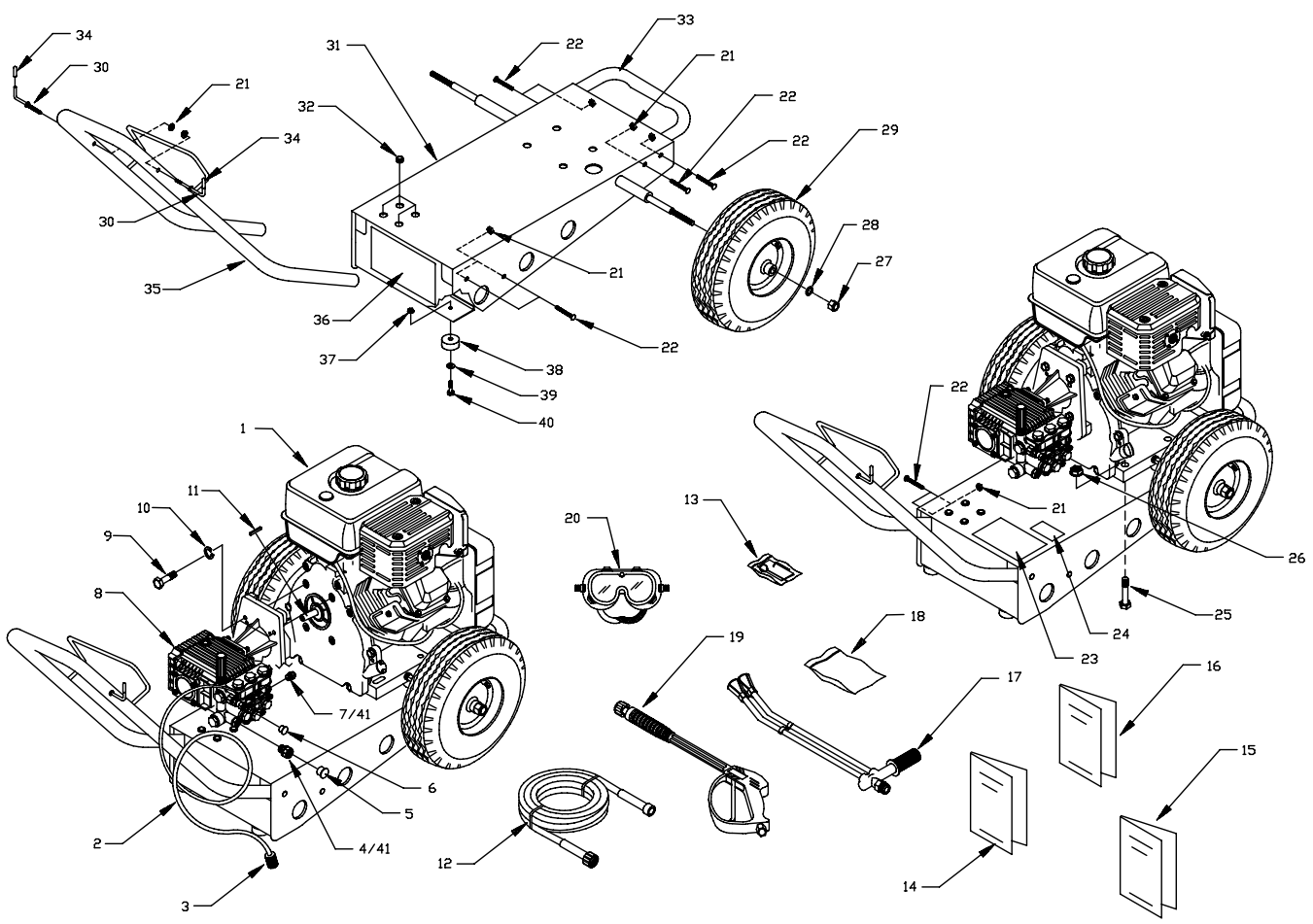

REPAIR PARTS — PRESSURE WASHER

Item	Part #	Qty.	Description
1	B2124	1	ENGINE, B&S Vanguard 9 HP
2	A1040B	1	HOSE, Chemical, 4'
3	A1041	1	FILTER, Chemical Hose
4	95320	1	INLET, Garden Hose
5	97098	1	CAP, Garden Hose Inlet
6	97100	1	CAP, H.P. Adaptor
7	B1554	1	VALVE, Thermal Relief
8	B2126	1	PUMP
9	B3040	4	HHCS, 5/16-24x1-1/8"
10	22129	4	WASHER, Lock
11	63281	1	KEY, 1/4" Square x 2" Lg.
12	B1621	1	HOSE, 3000 PSI
13	B2508	1	KIT, Nozzle Cleaning
14	B2832	1	MANUAL, Engine
15	B2131	1	MANUAL, Pump
16	B2128	1	MANUAL
17	B2140D	1	LANCE, Dual 1.2mm Dia.
18	B2684	1	KIT, Handle Hardware
19	B2500	1	GUN
20	87815	1	GOGGLES
21	99583	4	NUT, Hex Flange 5/16-18
22	B2043	4	BOLT, 5/16-18 x 1-3/4 Carriage
23	B2330	1	DECAL, Starting Instructions
24	20566	1	DECAL, 1-800 #
25	49541	4	HHCS, M10-1.5 35
26	52859	4	NUT, M10-1.5 Locking
28	26727	2	NUT, Hex 1/2 - 20 Nylok
29	89742	2	WHEEL, 12" Pneumatic
30	B2150	2	HOOK
31	AB2074A	1	BASE
32	30809	4	GROMMET, 1/8-11/16
33	B1982	1	BUMPER
34	B2516	2	CAP, Vinyl Black
35	B2075	1	HANDLE
36	B2130	1	DECAL, 3000 PSI
37	52858	2	NUT, M8-1.25 Locking
38	27007	2	MOUNT, Vibration
39	50190	2	WASHER, M8 Flat
40	42909	2	HHCS, M8-1.25x30
41	96727	.001 ML	LOCTITE, #680



LIMITED PRESSURE WASHER WARRANTIES (includes "Master Contractor")

GENERAC warrants to the original retail purchaser, the pressure washer manufactured by GENERAC to be free from defects in material and workmanship for the period(s) set forth below from the date of original purchase. This warranty is not transferable. The term "original purchaser" means the person for whom the pressure washer is originally purchased.

Warranty Schedules

Electric Power Washer	1 year (does not apply to commercial or rental operations)	
	CONSUMER*	COMMERCIAL*
Generac GN-Series Engine-driven Power Washer	Engine: 2 years (2nd year parts only) Pump: 1 year	1 year 90 days
All Other Engine-driven Power Washers	Engine: Warranted solely by Engine Manufacturer	Warranted solely by Engine Manufacturer
	Pump: 1 year	90 days

*** NOTE: For the purpose of this warranty "consumer use" means personal residential household use by original purchaser. "Commercial Use" means all other uses, including rental, construction, commercial and income producing purposes. Once a pressure washer has experienced commercial use, it shall thereafter be considered a commercial use pressure washer for the purposes of this warranty.**

During said warranty period, GENERAC will, at its option, repair or replace any part which, upon examination by GENERAC or GENERAC Authorized Dealers, is found to be defective under normal use and service**. All transportation costs under warranty, including return to the factory if necessary, are to be borne by the purchaser and prepaid by the purchaser.

**** NORMAL WEAR: As with all mechanical devices, the GN-Series engines need periodic parts service and replacement to perform well. This warranty will not cover repair when normal use has exhausted the life of a part or an engine.**

THIS WARRANTY DOES NOT INCLUDE: Used products and demonstration equipment. Parts such as GUNS, HOSES, DUAL LANCES, NOZZLES or other wear items such as quick couplers, oil, gauges, belts, O-rings, filters, pump packing, etc. Pumps which have been run without water supplied. Damage or malfunctions resulting from: accidents, abuse, modifications, alterations, or improper servicing. Freezing or chemical deterioration. Normal maintenance such as adjustments, fuel system cleaning and obstruction (due to chemical, dirt, carbon or lime, etc.).

THIS WARRANTY IS IN PLACE OF ALL OTHER WARRANTIES, EXPRESS OR IMPLIED, SPECIFICALLY, GENERAC MAKES NO OTHER WARRANTIES AS TO MERCHANTABILITY OR FITNESS FOR A PARTICULAR PURPOSE. The duration of any implied warranties which cannot be disclaimed is limited to the time period as specified in the express warranty. LIABILITY FOR CONSEQUENTIAL, INCIDENTAL, OR SPECIAL DAMAGES UNDER ANY AND ALL WARRANTIES IS EXCLUDED, EVEN IF SUCH DAMAGES ARE A DIRECT RESULT OF GENERAC'S NEGLIGENCE. Some states do not allow limitations on how long an implied warranty lasts, or the exclusion or limitation of incidental or consequential damages, so the above limitations or exclusions may not apply to you. This warranty gives you specific legal rights and you may also have other rights, which vary from state to state.

For service, see your nearest GENERAC authorized warranty service facility or call 1-800-333-1322. Warranty service can be performed only by a GENERAC authorized service facility. This warranty will not apply to service at any other facility. At the time of requesting warranty service, evidence of original purchase date must be presented.